

### LIMITED WARRANTY

The Manufacturer warrants to the original consumer purchaser that this product as manufactured is free from defects in materials and workmanship. For a period of two (2) years from date of purchase by the original consumer purchaser, we will repair or replace, at our option, without charge for parts or labor incurred in replacing parts, any part which we find to be defective due to materials or workmanship. This Warranty is subject to the following limitations and exclusions.

1. This warranty does not apply to the engine. Please refer to the applicable manufacturer's warranty on these items.
2. Transportation charges for the movement of any power equipment unit or attachment are the responsibility of the purchaser. Transportation charges for any parts submitted for replacement under this warranty must be paid by the purchaser unless such return is requested by your dealer.
3. The Warranty period for any products used for rental or commercial purposes is limited to 45 days from the date of original purchase.
4. This Warranty applies only to products which have been properly assembled, adjusted, operated, and maintained in accordance with the instructions furnished. This Warranty does not apply to any product which has been subjected to alteration, misuse, abuse, improper assembly or installation, delivery damage, or to normal wear of the product.
5. Exclusions: Excluded from this Warranty are belts, rotating lines, rotating line adapters, normal wear, normal adjustments, standard hardware and normal maintenance.
6. In case of any problem within the boundaries of this warranty, contact the nearest department store, indicate the model number, serial number and the date of purchase of your machine. This warranty does not apply to accidental damages. All implicit warranties are limited to the same time frames. Or contact:

E.M. Services  
54 Rue Lambrechts  
92400 Courbevoie  
France  
Telephone: (1) 46678078  
Fax: (1) 46678095

THIS WARRANTY DOES NOT APPLY TO INCIDENTAL OR CONSEQUENTIAL DAMAGES.  
ANY IMPLIED WARRANTIES ARE LIMITED TO THE SAME TIME PERIODS STATED  
HEREIN.

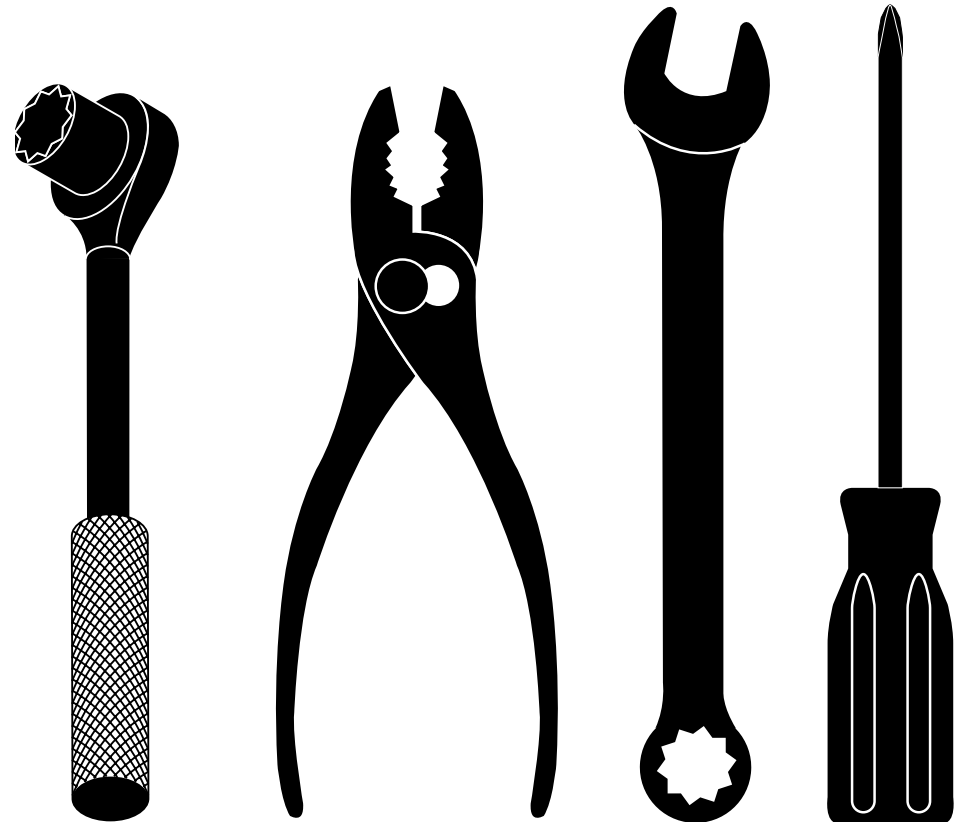

## REPAIR PARTS MANUAL MODEL NO. WT420 (PWT420A) Wheeled Weed Trimmer

 **Electrolux**

 **Electrolux**

**WEED TRIMMER - - MODEL NUMBER WT420 (PWT420A)  
PRODUCT NUMBER 964 77 74-00**

**SERVICE NOTES**

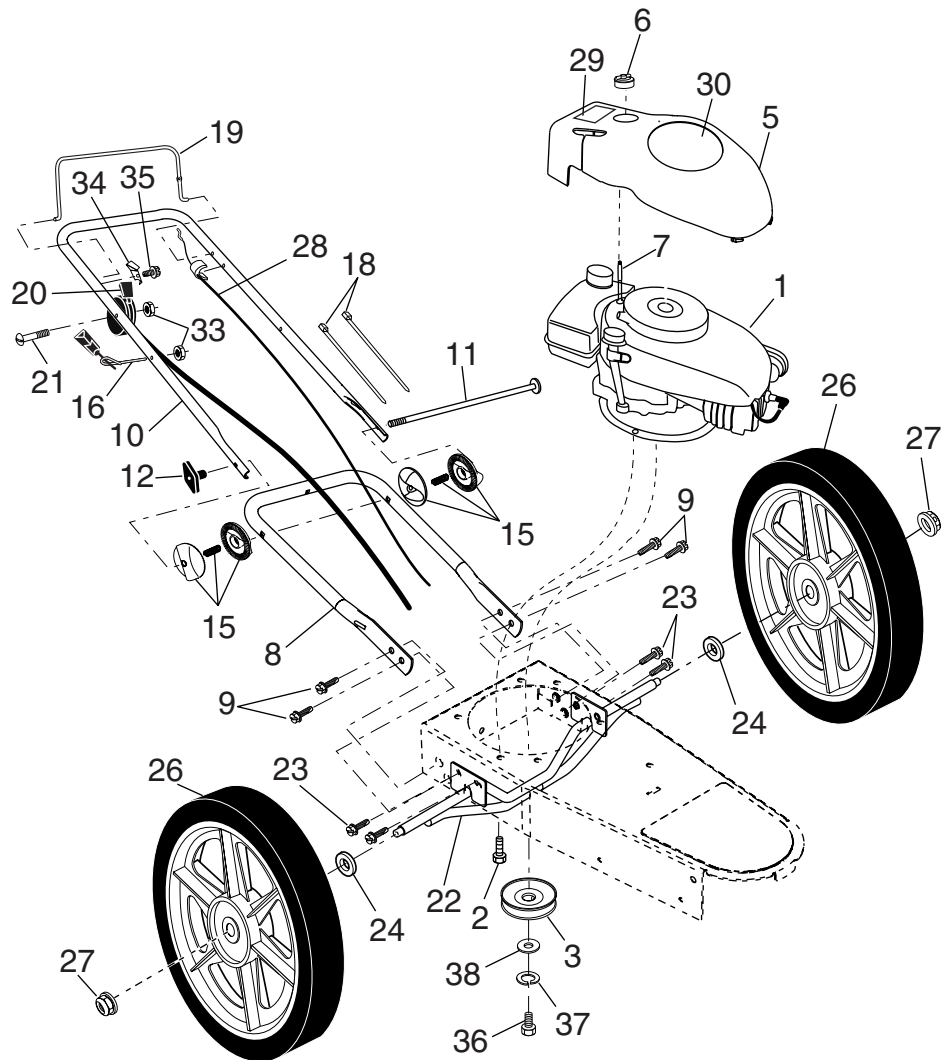

**SERVICE NOTES**

**WEED TRIMMER - - MODEL NUMBER WT420 (PWT420A)  
PRODUCT NUMBER 964 77 74-00**

<b>KEY NO.</b>	<b>PART NO.</b>	<b>DESCRIPTION</b>
1	- - -	Engine, Tecumseh, Model Number LEV120 (Order parts from Engine Manufacturer)
2	532 15 04-06	Bolt, Engine Mounting 3/8-16
3	532 17 94-66	Pulley, Engine (Includes Setscrew, Key #4)
5	532 18 17-01	Cover, Engine, with Screen
6	532 17 42-74	Knob, Engine Cover
7	532 17 40-30	Stud, Engine Cover
8	532 18 67-54	Handle, Lower
9	532 15 00-78	Screw, Hex Washer Head 5/16-18 x .75
10	532 18 67-55	Handle, Upper
11	532 17 09-80	Bolt, Handle
12	532 13 63-76	Knob, Handle
15	532 17 97-51	Handle Adjuster Assembly
16	532 17 95-85	Guide, Rope
18	532 06 64-26	Wire Tire
19	532 17 69-83	Control Bar
20	532 17 49-34	Throttle Control
21	532 15 87-55	Screw, Hex Washer Head
22	532 18 67-56	Axle Shaft Assembly
23	532 15 00-78	Screw, Hex Washer Head 5/16-18 x .75
24	532 05 21-60	Washer, Axle
26	532 17 02-58	Wheel, 14 x 2
27	532 08 39-23	Hex Flange Locknut 3/8-16
28	532 18 16-99	Drive Control Cable
29	532 17 40-34	Decal, Warning
30	532 17 83-03	Decal, Engine Cover
33	532 13 20-04	Nut
34	532 12 52-03	Bracket, Upstop
35	532 75 06-34	Screw, Thd. Roll. #10-24 x 5/8
36	532 85 10-84	Screw, Hex Head 3/8-24 x 1
37	532 85 02-63	Washer, Lock
38	532 85 10-74	Washer, Flat, Hardened
--	532 17 78-24	Operator's Manual, European
--	532 17 78-25	Operator's Manual, Scandanivan
--	532 18 64-85	Repair Parts Manual

**NOTE:** All component dimensions given in U.S. inches  
1 inch = 25.4 mm

**WEED TRIMMER - - MODEL NUMBER WT420 (PWT420A)**  
**PRODUCT NUMBER 964 77 74-00**

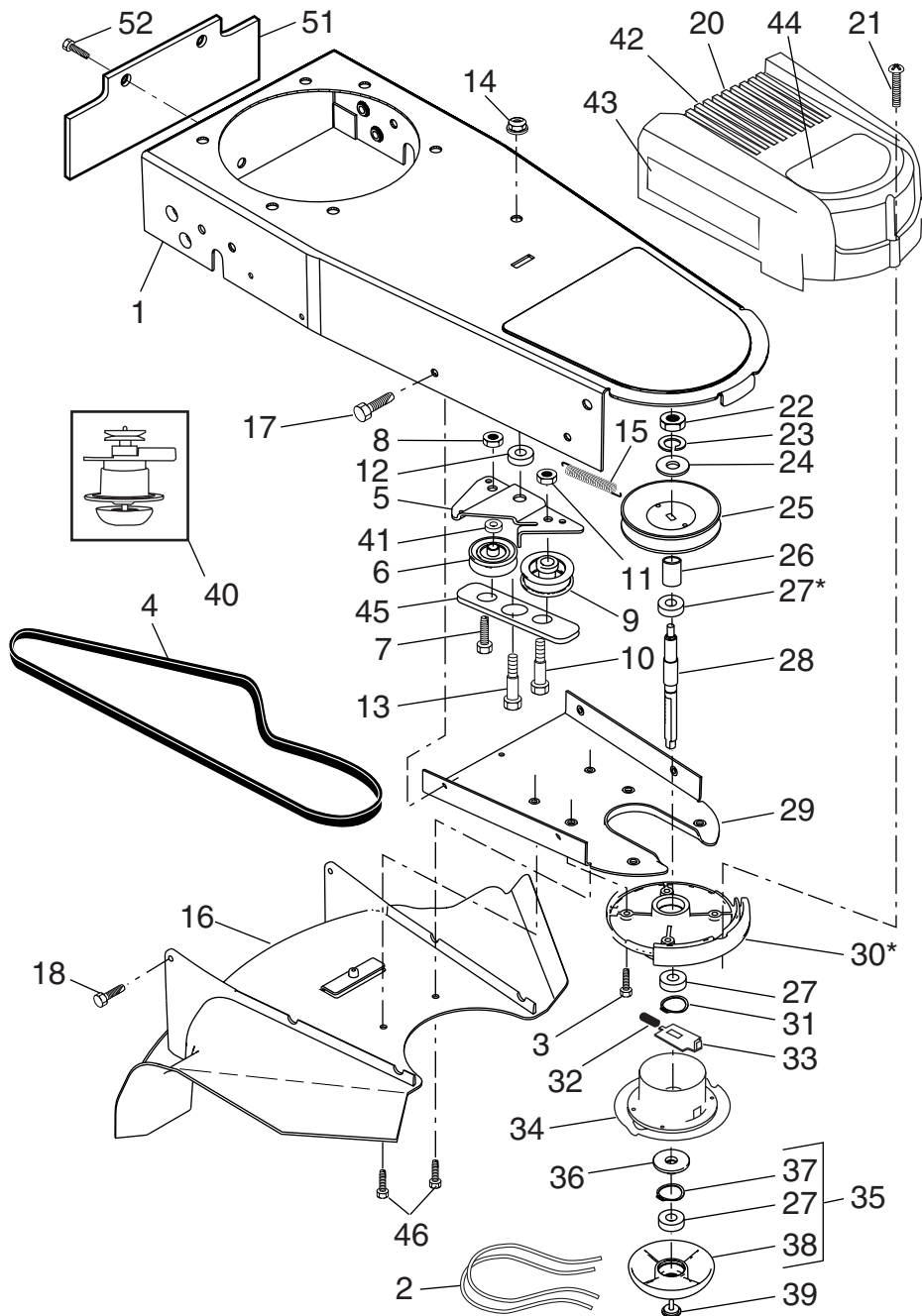

**WEED TRIMMER - - MODEL NUMBER WT420 (PWT420A)**  
**PRODUCT NUMBER 964 77 74-00**

KEY NO.	PART NO.	DESCRIPTION
1	532 18 67-60	Chassis Assembly
2	532 17 40-40	Line, Trimmer .155 diameter x 18.75 long
3	532 15 00-78	Screw, Self-Tapping 5/16-18 x 1
4	532 18 43-54	V-Belt
5	532 18 67-51	Bracket, Idler
6	532 16 60-42	Pulley, Idler, V-Groove
7	532 17 37-16	Bolt, Hex Head 3/8-16 x 1.25
8	532 75 15-92	Locknut, Hex 3/8-16
9	532 16 60-43	Pulley, Idler, Flat
10	532 16 08-29	Bolt, Shoulder
11	532 15 55-52	Locknut 5/16-18
12	532 17 37-17	Spacer
13	532 17 47-19	Bolt, Shoulder
14	532 14 52-12	Locknut, Flange
15	532 17 38-11	Spring, Return
16	532 18 02-68	Deflector, Bottom
17	532 05 78-08	Screw 1/4-20 x 1/2
18	532 17 88-48	Screw #10-24 x 3/4
20	532 17 83-90	Cover, Chassis, Top
21	532 14 97-46	Screw #10-24 x 1-3/4
22	532 05 48-57	Nut, Hex 3/8-24 UNF
23	532 45 61-20	Washer, Lock 3/8
24	532 05 17-85	Washer, Flat 3/8
25	532 18 03-40	Pulley, Driven
26	532 17 25-51	Spacer, Pulley
27	532 17 45-49	Bearing
28	532 17 25-20	Jackshaft
29	532 18 67-52	Cover, Chassis, Bottom
30	532 17 45-43	Spindle Housing Assembly (* Includes Upper Bearing, Key Number 27)
31	532 17 45-81	Ring, Retaining, External, 17mm
32	532 17 69-73	Spring, Locking Plate
33	532 17 25-19	Locking Plate
34	532 18 03-38	Carrier Plate Assembly
35	532 18 22-17	Mow Ball Assembly (Includes Key Numbers 27, 37 and 38)
36	532 17 25-16	Cover, Bearing
37	532 17 45-80	Ring, Retaining, Internal, 40mm
38	532 17 25-23	Mow Ball
39	532 18 03-34	Bolt, Mow Ball
40	532 18 03-33	Spindle Assembly, Complete (Includes Key Numbers 22-28 and 30-39)
41	532 17 40-29	Spacer
42	532 18 22-04	Decal, Safety
43	532 17 40-42	Decal, Instruction
44	532 17 82-16	Decal, Chassis Cover
45	532 18 67-53	Belt Keeper, Bottom
46	817 06 04-08	Screw, Self-Tapping
47	532 18 22-05	Decal, Instruction
51	532 17 98-75	Deflector, Rear
52	532 17 88-48	Screw

**NOTE:** All component dimensions given in U.S. inches  
 1 inch = 25.4 mm